

**MOUNTING INSTRUCTION:**

USE 2-56 MACHINE SCREWS OR EYELETS 0.089" OD BY 0.15" FLANGE STIMPSON GS-3 SERIES OR EQUIVALENT ALSO ADHESIVES AND DOUBLE SIDED TAPES WORK WELL.

Date	SYM	REVISION RECORD	AUTH	DR.	CK.
12/26/03	A	Changed Material Specification	T.B.	B.S.	
1/28/06	B	Added "ROHS COMPLIANT"	T.B.	B.S.	
10/28/06	C	Added Ø2.36 hole size to PCB layout	T.B.	B.S.	

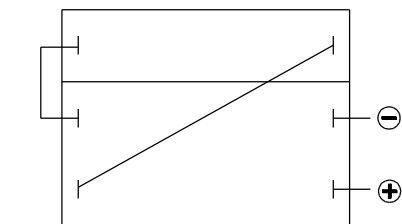
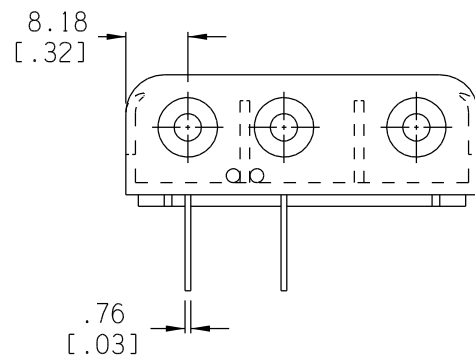
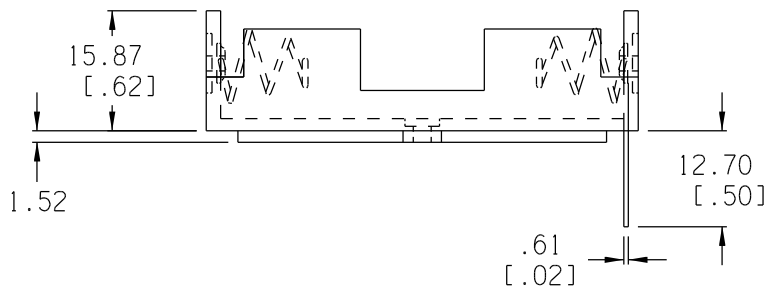
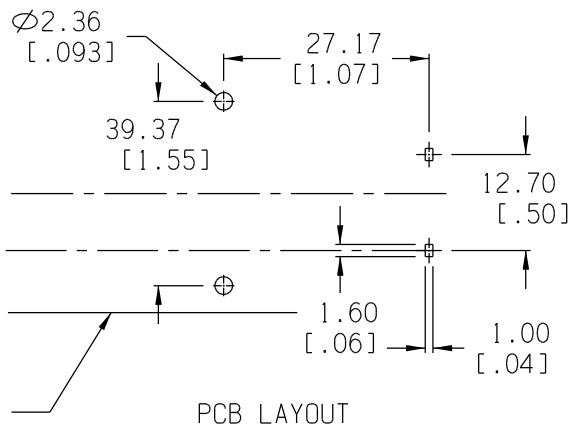

INTER CONNECTION SCHEMATIC

**NOTES:**

**MATERIAL:**

HOUSING: IMPACT RESISTANCE NYLON #6, BLACK, UL 94V-0, MATERIAL FILE #UL E 48285  
 SPRING: SPRING STEEL, NICKLE PLATED  
 CONTACTS: SPRING STEEL, NICKLE PLATED  
 EYELETS: BRASS, NICKLE PLTD.  
 JUMPER: #24 AWG, 2.5" LONG  
 ROHS COMPLIANT

Tolerance (Inches)	 <b>Memory Protection Devices, Inc</b> 200 Broad Hollow Road, Farmingdale, New York 11735		
Decimal		Scale	Drawn By B.S.
±.5 (.020)			Approved By T.B.
Fractional	Title		
± .8 (.030)	3AA BATTERY HOLDER WITH PC PINS		
Angular	Date	Drawing Number	
± 3°	10/28/06	BH3AA-PC	